



Features

Exterior stainless steel with galvanized back and bottom reduces risk of corrosion.

Interior aluminum with coved corners and finished edges for easy cleaning.

Environmentally friendly polyurethane foamed-in-place insulation for maximum strength and durability.

Full extension drawers This premier slide and framework construction promotes lateral stability while offering high dynamic load capacities and a stay-shut feature. All drawers accommodate full size 12" x 20" x 6" deep hotel pans and deep fractional pans. Drawers lift out for cleaning.

3 Wire power cord is a standard 7 feet in length.

Santoprene™ gaskets last four times longer than the industry standard.

CFC-free refrigerant hermetically sealed, high efficiency, self contained refrigeration system with automatic defrost and forced air circulation.

Heavy-duty casters secured to a 12 gauge steel base to ensure years of worry free operation.

Limited Warranty: 1-year labor, 1-year parts, 5-year compressor (part only), 90-days replacement parts. Warranty is determined by the original equipment manufacturing date for general market. *

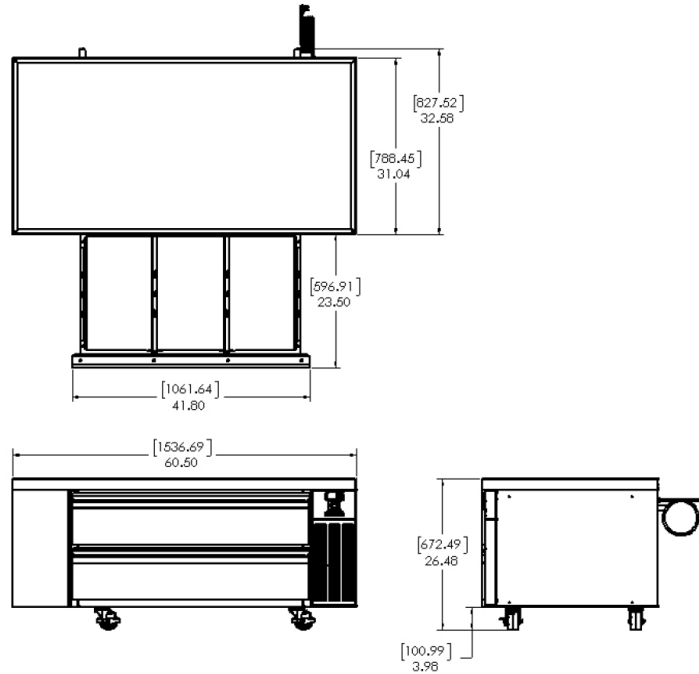

Technical Specifications

Dimensions

Model Number	Width in (mm)	Height in (mm)	Depth in (mm)	Gross Shipping Wgt lb (kg)	Unit Shipping Wgt lb (kg)	Shipping cu ft (cu m)
SKRCB60H-RDEU10	60.50 (1536.69)	26.48 (672.49)	32.58 (827.52)	440 (199.58)	400 (181.45)	38.80 (1.10)
SKRCB60H-RDUK10	60.50 (1536.69)	26.48 (672.49)	32.58 (827.52)	440 (199.58)	400 (181.45)	38.80 (1.10)

Electrical

Model Number	Country of Origin	Amps	Voltage	Hz	Plug	Refrigerant
SKRCB60H-RDEU10	USA	2.5	115VAC	60	TYPE "E"	R134A
SKRCB60H-RDUK10	USA	2.5	115VAC	60	TYPE "G"	R134A

Certifications



To learn more about our **Refrigerated Chef Bases**, visit silverking.com
To contact us directly, go to silverking.com/contact