



## Features

### **Eco-Friendly Refrigerant**

R290 refrigerant with a global warming potential (GWP) of 3

### **Elevated Countertop Compartments**

Elevated rail holds up to twelve (12) 1/3 size pans and positions key ingredients closer to the crew — pan adapters included

### **High-Efficiency Refrigeration System**

Forced air circulation provides uniform temperature throughout the cabinet

### **Easy to Clean**

Aluminum interior, coved corners, finished edges, removable cutting board, and top compartment crumb tray for simple cleaning

### **High-Density Insulation**

Foamed-in-place, CFC-free polyurethane insulation for maximum strength, rigidity, and insulation

### **Large 19" Cutting Board**

Removable 19" polyethylene cutting board provides a durable work surface

### **Drawer Capacity**

Each drawer includes one (1) divider bar to accommodate two (2) full-size 12" W x 20" H x 6" D hotel pans — additional adapters are available for fractional pans

### **Stainless Steel Exterior**

Galvanized back and bottom to reduce the risk of corrosion

### **Magnetic 'Thermo Rubber' Gaskets**

Heavy-duty, stainless steel doors with magnetic 'Thermo Rubber' gaskets ensure an air-tight cabinet

### **Heavy-Duty Soft Casters**

Secured to a 12 gauge steel base to ensure years of worry-free operation

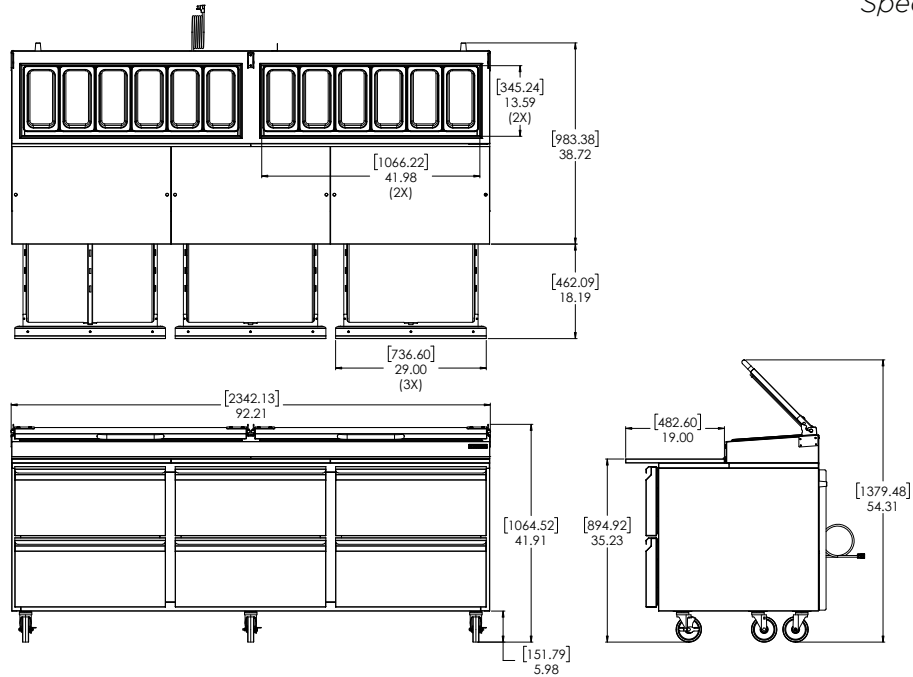

## Technical Specifications

<b>Electrical Requirements</b>	115v/60hz/1ph/5.3A/NEMA 5-15P Plug
<b>Product Dimensions</b>	92.21"W x 41.91"H x 38.72"D (234.21cm x 106.45cm x 98.35cm)
<b>Product Weight</b>	635lbs (288.03kg)
<b>Shipping Dimensions</b>	96"W x 48"H x 38"D (243.84cm x 121.92cm x 96.52cm)
<b>Shipping Weight</b>	675lbs (306.17kg)
<b>Shipping Cubic Dimensions</b>	101.33ft <sup>3</sup> (2.87Cu.M <sup>3</sup> )
<b>Temperature Range</b>	36 to 40°F (2.2 to 4.4°C)
<b>Refrigerant</b>	R290
<b>Insulation</b>	Foamed-in-place, CFC-free polyurethane
<b>Exterior Construction</b>	Stainless steel exterior with galvanized bottom

<b>Interior Construction</b>	Aluminum interior with coved corners and finished edges
<b>Drawers</b>	Six (6) high-strength, full-extension drawers with dividers
<b>Lid</b>	Two (2) hinged stainless steel, insulated (removable)
<b>Pan Well Capacity</b>	Supplied with twelve (12) 1/3 size pans (6" deep)
<b>Internal Capacity</b>	Accommodates twelve (12) full-size 12" W x 20" H x 6" D hotel pans
<b>Drawer Gasket</b>	Santoprene™ gasket
<b>Cutting Board</b>	Three (3) 19" deep polyurethane cutting boards (removable)
<b>Casters</b>	Six (6) 5" heavy-duty soft casters (three locking)
<b>Certifications</b>	ETL SAFETY, ETL SANITATION
<b>Warranty</b>	1-year parts and labor, 5-year compressor (part only)

Model Number	Description
SKPZ92-EDUS1	Prep Table, 92", 115v/60hz/1ph, 6 drawer, 5" heavy-duty casters (three locking), 19"D cutting board, NEMA 5-15P

Accessories	Description
25567	Adapter Bars for Fractional Pans
43581	Pan 1/6 Size, 4" Deep Plastic
43643	Pan 1/6 Size, 6" Deep Plastic
27066	Pan 1/3 Size, 4" Deep Plastic
26415	Pan 1/3 Size, 6" Deep Plastic

To learn more about **Pizza Prep Table**, visit [silverking.com](http://silverking.com)