



## Features

### **Eco-Friendly Refrigerant**

R290 refrigerant with a global warming potential (GWP) of 3

### **High-Strength, Full-Extension Drawers**

Premium slide and framework construction promotes lateral stability while offering high dynamic load capacities and a stay-shut feature

### **Stainless Steel Exterior**

Galvanized back and bottom to reduce the risk of corrosion

### **Long-Lasting, Removable Gaskets**

Santorprene™ gaskets last four times longer than standard gaskets

### **Heavy-Duty Soft Casters**

Secured to a 12 gauge steel base to ensure years of worry-free operation

### **High-Efficiency Refrigeration System**

Forced air circulation provides uniform temperature throughout the cabinet while automatic defrost self-manages ice buildup and evaporates moisture

### **Drawer Capacity**

Each drawer includes two (2) divider bar to accommodate three (3) full size 12"W x 20"H x 6"D hotel pans — additional pan adapters are available for fractional pans

### **Easy to Clean**

Aluminum interior, coved corners, finished edges, plus full-extension and easy lift out drawers

### **High-Density Insulation**

Foamed-in-place, CFC-free polyurethane insulation for maximum strength, rigidity, and insulation

### **Marine Edge**

Also called a no-drip edge, the marine edge captures splashes or spills to limit cleanup

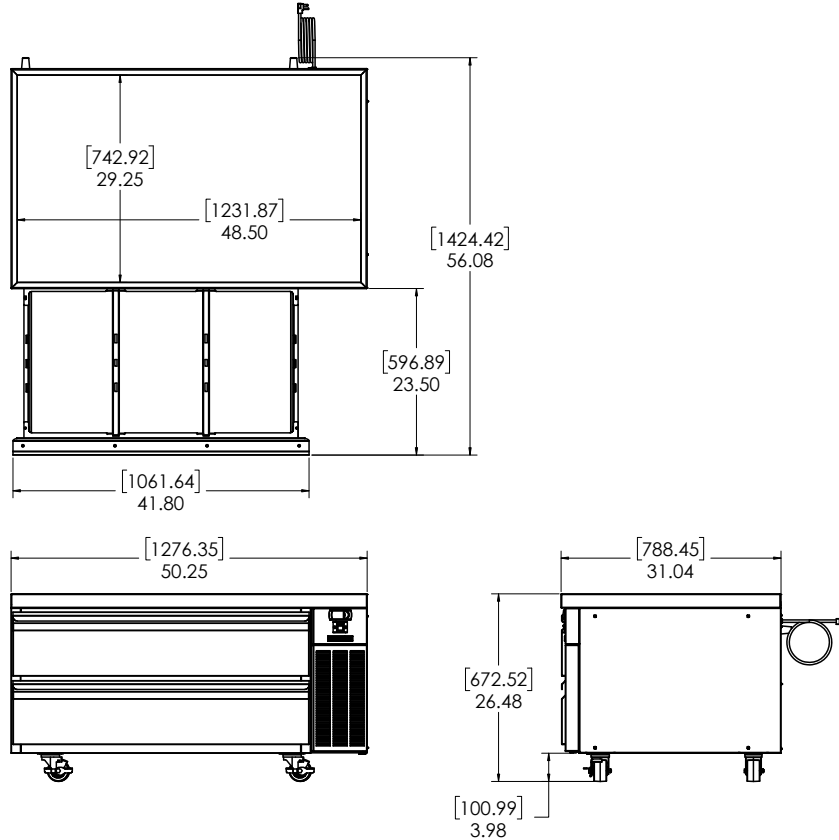

## Technical Specifications

<b>Electrical Requirements</b>	115v/60hz/1ph/4.8A/NEMA 5-15P Plug
<b>Product Dimensions</b>	50.25"W x 26.47"H x 32.58"D (127.64cm x 67.23cm x 82.75cm)
<b>Product Weight</b>	330lbs (149.69kg)
<b>Shipping Dimensions</b>	55"W x 30"H x 36"D (139.70cm x 76.20cm x 91.44cm)
<b>Shipping Weight</b>	355lbs (161.03kg)
<b>Shipping Cubic Dimensions</b>	34.38ft <sup>3</sup> (0.97m <sup>3</sup> )
<b>Temperature Range</b>	-5 to 0°F (-20.5 to 17.7°C)
<b>Refrigerant</b>	R290
<b>Insulation</b>	CFC-free polyurethane foam-in-place insulation

<b>Exterior Construction</b>	Stainless steel exterior with galvanized back and bottom
<b>Interior Construction</b>	Aluminum interior with coved corners and finished edges
<b>Drawers</b>	Two (2) high-strength, full-extension drawers with dividers
<b>Capacity</b>	Six (6) full-size 12"W x 20"H x 6"D hotel pans
<b>Door/Drawer Gasket</b>	Santoprene™ gasket
<b>Casters</b>	Four (4) 4" heavy-duty soft casters (two locking)
<b>Certifications</b>	ETL Safety, ETL Sanitation
<b>Warranty</b>	1-year parts and labor, 5-year compressor (part only)

Model Number	Description
SKFCB50H-EDUS1	Chef Base Freezer 50", 115v/60hz/1ph/4.8A, marine edge, 2 drawer, 4" heavy-duty soft casters (two locking), NEMA 5-15P

Accessories	Description
25567	Adapter Bars for Fractional Pans
43581	Pan 1/6 Size, 4" Deep Plastic
43643	Pan 1/6 Size, 6" Deep Plastic
27066	Pan 1/3 Size, 4" Deep Plastic
26415	Pan 1/3 Size, 6" Deep Plastic

To learn more about **Chef Base Freezer**, visit [silverking.com](http://silverking.com)