



Features

Eco-Friendly Refrigerant

R290 refrigerant with a global warming potential (GWP) of 3

Elevated Countertop Compartments

Elevated rail holds up to eight (8) 1/3 size pans and positions key ingredients closer to the crew — pan adapters included

High-Efficiency Refrigeration System

Forced air circulation provides uniform temperature throughout the cabinet

Easy to Clean

Aluminum interior, coved corners, finished edges, removable cutting board, and top compartment crumb tray for simple cleaning

High-Density Insulation

Foamed-in-place, CFC-free polyurethane insulation for maximum strength, rigidity, and insulation

Large 16" Cutting Board

Removable 16" polyethylene cutting board provides a durable work surface

Drawer Capacity

Each drawer includes one (1) divider bar to accommodate two (2) full-size 12" W x 20" H x 6" D hotel pans — additional adapters are available for fractional pans

Stainless Steel Exterior

Galvanized back and bottom to reduce the risk of corrosion

Magnetic 'Thermo Rubber' Gaskets

Heavy-duty, stainless steel doors with magnetic 'Thermo Rubber' gaskets ensure an air-tight cabinet

Heavy-Duty Soft Casters

Secured to a 12 gauge steel base to ensure years of worry-free operation

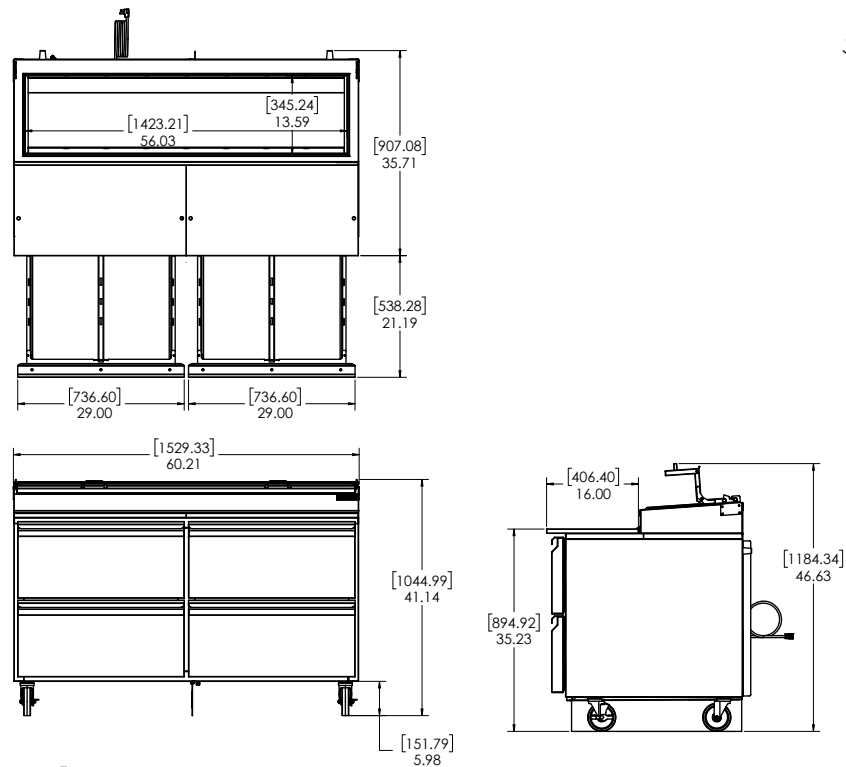

Technical Specifications

Electrical Requirements	115v/60hz/1ph/2.8A/NEMA 5-15P Plug
Product Dimensions	60.21"W x 41.14"H x 35.71"D (152.93cm x 104.50cm x 90.70cm)
Product Weight	500lbs (226.80kg)
Shipping Dimensions	65"W x 47"H x 38"D (165.10cm x 119.38cm x 96.52cm)
Shipping Weight	530lbs (240.40kg)
Shipping Cubic Dimensions	67.18ft ³ (1.90Cu.M ³)
Temperature Range	36 to 40°F (2.2 to 4.4°C)
Refrigerant	R290
Charge Level	5.3oz (150 grams)
Insulation	Foamed-in-place, CFC-free polyurethane

Exterior Construction	Stainless steel exterior with galvanized bottom
Interior Construction	Aluminum interior with coved corners and finished edges
Drawers	Four (4) high-strength, full-extension drawers with dividers
Lid	Tri-fold 3-position stainless steel (removable)
Pan Well Capacity	Supplied with six (6) 1/3 size pans and four (4) 1/6 size pans (4" deep) – can accommodate up to 6" deep pans
Drawer Capacity	Accommodates eight (8) full-size 12" W x 20" H x 6" D hotel pans
Drawer Gasket	Santoprene™ gasket
Cutting Board	Two (2) 16" deep polyurethane cutting boards (removable)
Casters	Four (4) 5" heavy-duty soft casters (two locking)
Certifications	ETL SAFETY, ETL SANITATION
Warranty	1-year parts and labor, 5-year compressor (part only)

Model Number	Description
SKPZ60-EDUS11	Prep Table, 60", 115v/60hz/1ph, 4 drawer, 5" heavy-duty casters (two locking), tri-fold lid, 16"D cutting board, (8) 1/3 size 4"D pans, NEMA 5-15P

Accessories	Description
25567	Adapter Bars for Fractional Pans
43581	Pan 1/6 Size, 4" Deep Plastic
43643	Pan 1/6 Size, 6" Deep Plastic
27066	Pan 1/3 Size, 4" Deep Plastic
26415	Pan 1/3 Size, 6" Deep Plastic

To learn more about **Pizza Prep Table**, visit silverking.com