



Features

Eco-Friendly Refrigerant

R290 refrigerant with a global warming potential (GWP) of 3

Crew-Proof Construction

Stainless steel exterior, galvanized bottom to reduce the risk of corrosion, and heavy-duty soft casters

Insulated Lids

Removable, front and back hinged lids for easy access

Cabinet Capacity

Maximized interior storage area of 2.45 cubic feet

Mobility

3" heavy-duty soft casters plus a sleek design allow for easy movement around the kitchen

Easy to Clean

Stainless steel interior with coved corners, finished edges, plus removable front lid and rear cover

High-Density Insulation

Foamed-in-place, CFC-free polyurethane insulation for maximum strength, rigidity, and insulation

Cold Wall Refrigeration System

Optimized temperature control thanks to the cold wall refrigeration and top access

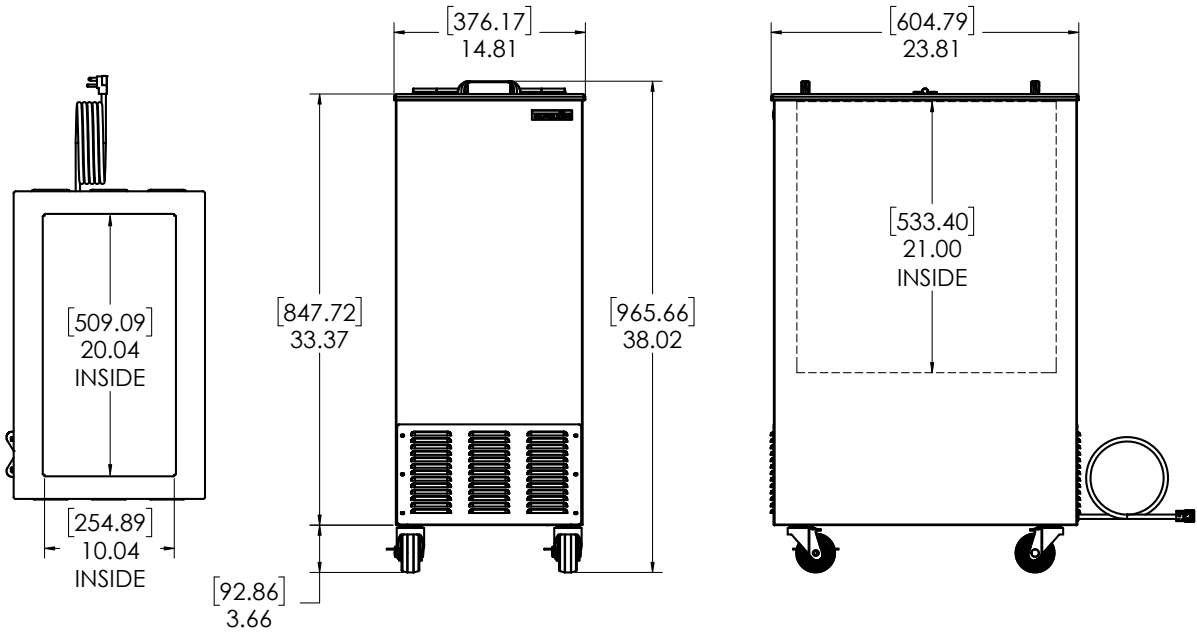

Technical Specifications

Electrical Requirements	230v/50-60hz/1ph/2.1A/TYPE G Plug
Product Dimensions	14.81"W x 38.02"H x 23.81"D (37.62cm x 96.57cm x 60.48cm)
Product Weight	110lbs (49.90kg)
Shipping Dimensions	28"W x 42"H x 20"D (71.12cm x 106.68cm x 50.80cm)
Shipping Weight	125lbs (56.70kg)
Shipping Cubic Dimensions	13.61ft ³ (0.39m ³)
Temperature Range	-5 to 5°F (-20.6 to -15°C)
Refrigerant	R290
Charge Level	2.3 oz (65.2 grams)

Insulation	Foamed-in-place, CFC-free polyurethane
Exterior Construction	Stainless steel exterior with galvanized bottom
Interior Construction	Stainless steel interior with covered corners and finished edges
Lids	Front and back, insulated, hinged, removable
Internal Capacity	2.45ft ³
Casters	Four (4) 3" heavy-duty soft casters (two locking)
Certifications	ETL SAFETY, ETL SANITATION
Warranty	1-year parts and labor, 5-year compressor (part only)

Model Number	Description
SKFI15-ELUK2	Mobile freezer 15", 230v/50-60hz/1ph, insulated hinged lids, 3" heavy-duty soft casters (two locking), TYPE G Plug

To learn more about **Mobile Freezer**, visit silverking.com