



Features

Eco-Friendly Refrigerant

R290 refrigerant with a global warming potential (GWP) of 3

Cabinet Capacity

Internal area of 12.99ft³ with two (2) heavy-gauge wire shelves — adjustable in 1/2" increments using stainless steel pilasters

Easy to Clean

Aluminum interior with coved corners and finished edges, removable shelf, plus a top compartment crumb tray

Magnetic 'Thermo Rubber' Gaskets

Heavy-duty, stainless steel doors with magnetic Thermo Rubber gaskets ensure an airtight cabinet

Heavy-Duty Soft Casters

Secured to a 12-gauge steel base to ensure years of worry-free operation

Elevated Refrigerated Rail

Raise key ingredients closer to the crew for easy access — holds up to seven (7) 3-1/2 quart food jars

High-Efficiency Refrigeration System

Forced air circulation provides a uniform temperature throughout the cabinet

Refrigerated Countertop Compartment

Keep key ingredients always within reach — holds food jars or pans with pan adapters included

High-Strength Doors

Heavy-duty, stainless steel doors assembled using high-load brackets for long-lasting durability

Stainless Steel Exterior

Galvanized back and bottom reduces the risk of corrosion

High-Density Insulation

Foamed-in-place, CFC-free polyurethane insulation for maximum strength, rigidity, and insulation

Cutting Board

Removable 6" polyethylene cutting board provides a large durable work surface

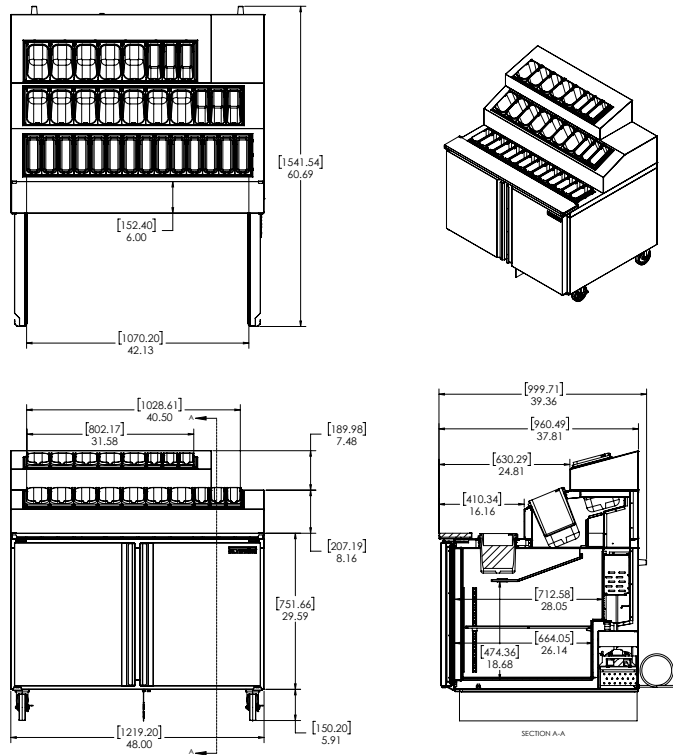

Technical Specifications

Electrical Requirements	115v/60hz/1ph/4.4A/NEMA 5-15P Plug
Product Dimensions	48"W x 44.79"H x 33.7"D (121.92cm x 113.77cm x 85.60cm)
Product Weight	295lbs (133.81kg)
Shipping Dimensions	53"W x 47"H x 34"D (134.62cm x 119.38cm x 86.36cm)
Shipping Weight	325lbs (147.42kg)
Shipping Cubic Dimensions	47.97ft ³ (1.36m ³)
Temperature Range	36 to 40 (2.2 to 4.4°C)
Refrigerant	R290
Charge Level	3.2oz (90.7 grams)

Insulation	Foamed-in-place, CFC-free polyurethane
Exterior Construction	Stainless steel exterior with galvanized back and bottom
Interior Construction	Aluminum interior with covered corners and finished edges
Doors	Two doors, one (1) left-hand and one (1) right-hand swing
Internal Capacity	12.99ft ³
Rail Temperature	36 to 40°F
Door Gasket	Santoprene™
Shelves	Two (2) heavy-gauge wire shelves, removeable
Casters	Four (4) 5" heavy-duty soft casters, two (2) locking
Certifications	ETL Safety, ETL Sanitation
Warranty	1-year parts and labor, 5-year compressor (part only)

Model Number	Description
SKRN48-ESUS1	Fountainette, 48", 115v/60hz/1ph, two doors, 6" cutting board, 5" heavy-duty casters (two locking), NEMA 5-15P

To learn more about **Refrigerator**, visit silverking.com