

# Technical Manual & Replacement Parts List

---

## Freezer



**MODEL: SKF27A-ED 115V**

1600 Xenium Lane North, Minneapolis, MN 55441-3787  
Phone (763) 923-2441

**SILVER KING<sup>®</sup>**

FORM NO. 45071 REV D 07/2021

Specifications Subject to Change Without Notice.



## TECHNICAL MANUAL

### SILVER KING FRONT BREATHING FREEZER

### MODEL SKF27A-ED

Thank you for purchasing Silver King food service equipment. Our goal is to provide our customers with the most reliable equipment in the industry today. Please read this manual and the accompanying warranty information before operating your new Silver King unit.

#### **INSPECT FOR DAMAGE AND UNCRATE**

Upon delivery of your new Silver King unit, uncrate at once to examine and test for possible damage following the instructions printed on the exterior of the container. Report any damages to the carrier responsible for transportation and promptly present a claim for any evidence of mishandling. Save all packaging materials if a claim must be filed.

#### **PRECAUTIONS BEFORE USING THIS PRODUCT**

- This appliance is not intended for use by persons (including children) with reduced physical, sensory or mental capabilities, or lack of experience and knowledge, unless they have been given supervision or instruction concerning use of the appliance by a person responsible for their safety.
- Use caution when cleaning the condenser, the fins are very sharp.
- For units with a dual hertz rating, no adjustments are required for normal operation.
- If the supply cord is damaged, it must be replaced by the manufacturer, its service agent or similarly qualified persons in order to avoid a hazard.
- This refrigeration unit is not intended to be used at altitudes higher than 2000 meters.
- Do not store explosive substances such as aerosol cans with a flammable propellant in this appliance.
- Do not exceed the maximum load capacity of 75 pounds per drawer.
- Use caution when moving, installing, maintaining and using this refrigeration device to avoid either damaging the refrigerant tubing or increasing the risk of a leak.
- All component parts must be replaced with like components and all servicing must be done by factory authorized service personnel, so as to minimize the risk of possible ignition due to incorrect parts or improper service.
- If the unit has recently been transported on its side (or placed horizontally), then please let unit stand with the casters (or feet) on the ground for a minimum of 24 hours before plugging it in.

#### **FOR HYDROCARBON UNITS ONLY (R290)**

**Danger** – Risk of fire or explosion. Flammable refrigerant used. To be repaired only by trained service personnel. Do not puncture refrigeration tubing.

**Danger** – Risk of fire or explosion. Flammable refrigerant used. Do not use mechanical devices to defrost refrigerator/freezer. Do not puncture refrigeration tubing.

**Caution** – Risk of fire or explosion. Flammable refrigerant used. Consult repair manual/owner's guide before attempting to service this product. All safety precautions must be followed.

**Caution** – Risk of fire or explosion. To be repaired only by trained service personnel. Use only Silver King approved replacement parts. Flammable refrigerant used.

**Caution** – Risk of fire or explosion. Dispose of properly in accordance with federal or local regulations. Flammable refrigerant used.

## INSTALLATION

The stainless steel exterior of the cabinet has been protected by a plastic covering during manufacturing and shipping. This covering can be readily stripped before installation. After removing this covering, wash the interior and exterior surfaces using a warm, mild soapy water solution and a sponge or soft cloth. Rinse afterward with clean water and wipe dry. Do not use chlorinated cleaners.

### Location:

When locating your new Silver King unit, convenience and accessibility are important considerations, but the following installation guidelines must be observed;

- Always avoid locating the unit adjacent to an oven, heating element or hot air source which could adversely affect the performance of the unit.
- The unit must be level.
- For proper ventilation, the bottom front of the unit must not be obstructed.

### Legs/Casters:

Models without a base come with Legs or Casters. To install them, tilt the unit and thread the Legs or Casters into the four Rivnuts in the bottom of the cabinet. Make sure that they are installed tightly to prevent future thread wear.

### Drawers:

To remove the Drawers for cleaning, simply open them fully, pull the stop levers out on the Cabinet Drawer Tracks, and lift up and pull the Drawer out. To reinstall the Drawer, line up the Drawer Tracks on the cabinet and the Drawer, push the Drawer into the cabinet, then push locks back into place. The Drawer Pan can be removed by lifting it out with the Drawer fully extended.

### Electrical Connections

Be sure to check the data plate, located on the liner of the cabinet, for required voltage prior to connecting the unit to power. The specifications on the data plate supersede any future discussion.

Your Silver King refrigerator is equipped with an eight (8) foot power cord. Any attempt to modify the plug will void the warranty, terminate the manufacturers responsibility, and could result in serious injury.

If the supply cord is damaged, it must be replaced by the manufacturer, its service agent or similarly qualified persons in order to avoid a hazard.”

The circuit must be protected with a 15 or 20 ampere fuse or breaker. The unit must be isolated on a circuit and not plugged into an extension cord.

### Climate Class Rating

Your Silver King freezer has a climate class 4 rating. It is designed for use in areas not exceeding 30°C (86°F).



**WARNING:** This product can expose you to chemicals including lead, which are known to the State of California to cause cancer, birth defects, or other reproductive harm.

## **OPERATION**

### **Initial Start Up:**

After satisfying the installation requirements, the unit is ready to start. The unit will start when the power cord is connected to the required power source. If the compressor does not start when the unit is initially plugged in, check to make sure that the temperature control is not in the 'off' position. Allow the unit to run a minimum of two hours before loading it with product. When loading the unit with product, take care not to block the air flow at the back of the cabinet as this would affect the performance of the cabinet.

### **Temperature Control**

The Temperature Control is located on the back of the cabinet and is factory set to maintain an average cabinet temperature of approximately 0 Deg F. To obtain colder temperatures, press and hold the set button until the set point value flashes. Use the up or down arrow buttons to change the value and then press the set button again. Allow the unit a minimum of one hour to respond to a control setting adjustment.

### **Defrost:**

Your Silver King unit is an automatic defrost unit. No additional plumbing is required. Automatic defrosting is accomplished by a defrost heater and timer. Defrost water is collected in a pan located in the compressor compartment where it is evaporated into the room air. It is important that the unit be level so the condensate can drain properly.

## **MAINTENANCE**

Preventative maintenance is minimal although these few steps are very important to continued operation and maximizing the life of the appliance.

### **Cabinet Surfaces:**

The cabinet interior is aluminum and the exterior is stainless steel. These surfaces should be cleaned periodically with a solution of warm water and mild soap. After cleaning the surfaces, they should be rinsed with clean water and wiped dry with a soft cloth. Stainless steel cleaners can be used on the exterior. Should a surface become stained, do not attempt to clean with an abrasive cleaner or scouring pad. Use a soft cleanser and rub with the grain of the metal to avoid scratching the surface. Always rinse well and dry after cleaning. Do not use chlorinated cleaners.

### **Condenser**

Periodically, accumulated dust must be removed from the condenser. First, disconnect the unit from the power supply. To clear the dust, vacuum or brush the condenser at the bottom rear of the cabinet. This will need to be done regularly to maintain the compressor warranty!

**WARNING: The condenser fins are very sharp, use caution when cleaning the condenser.**

### **Drawer Gasket**

The Drawer Gasket will collect dirt and should be wiped clean with a warm, mild soapy water solution to extend its life and assure maximum cabinet performance and life.

MODEL \_\_\_\_\_ SERIAL NO. \_\_\_\_\_ DATE INSTALLED \_\_\_\_\_

# AIR CURTAIN INSTALLATION INSTRUCTIONS

APPLIES TO THESE MODELS: SKP278A, SKP2712A, SKP2727(D), SKR27A(D), SKF27A(D), SKR48A, SKF48A, SKP4812A, SKP6024(D), SKP60(D), SKPZ72(D), SKPZ92(D)

## DO NOT OPERATE UNIT WITHOUT AIR CURTAIN INSTALLED

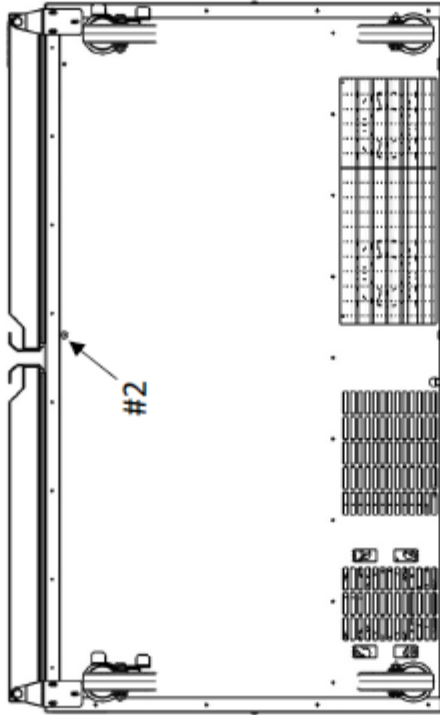

SKR48A SHOWN

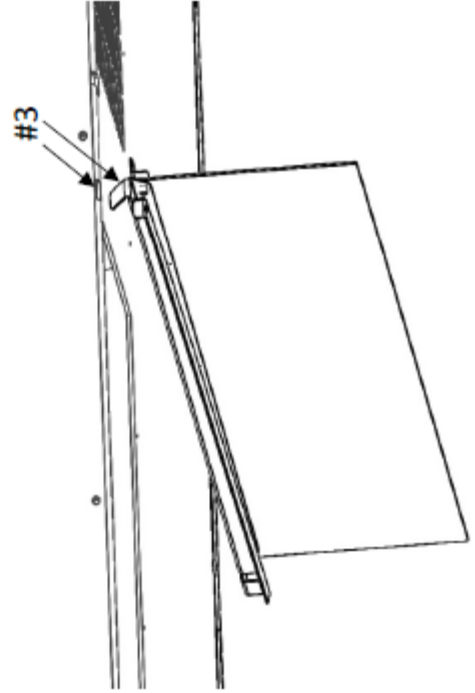

1. Disconnect unit from power source.
2. Tip the unit on its back and loosen the center screw along the front bottom edge of the base.
3. Insert the tab on the end of the air curtain into the slot located along the rear lower edge of the unit.
4. Slip the opposite end of the air curtain under the screw head loosened in step #2 and tighten screw to secure the air curtain to the base.
5. Return unit to original upright position.

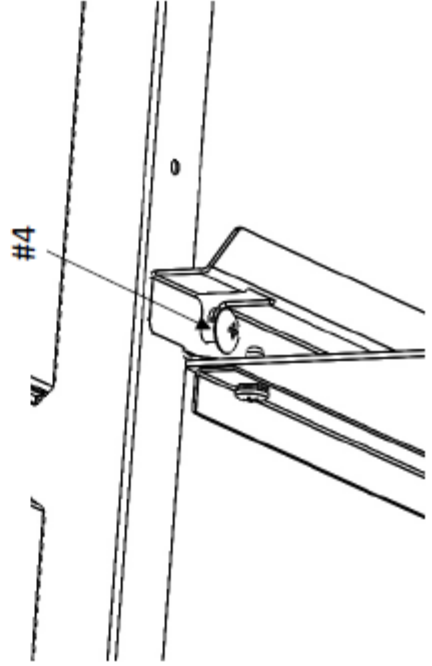

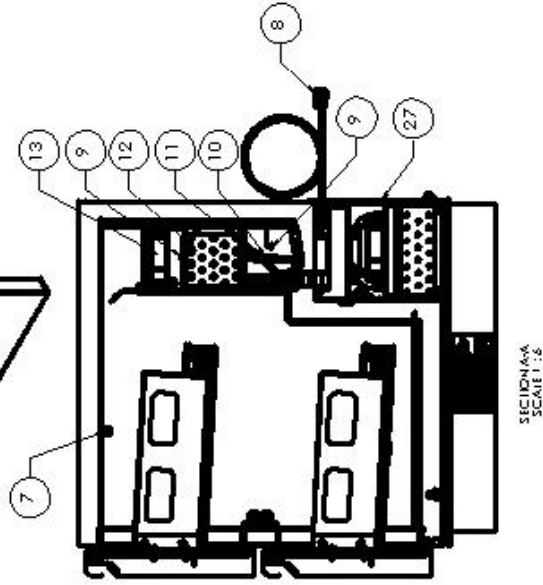
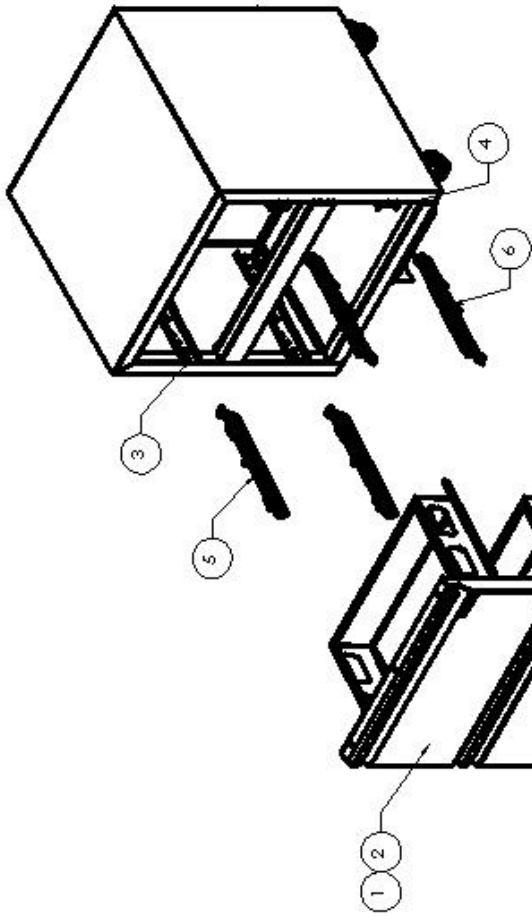

SECCIONADA  
SCALE 1:3

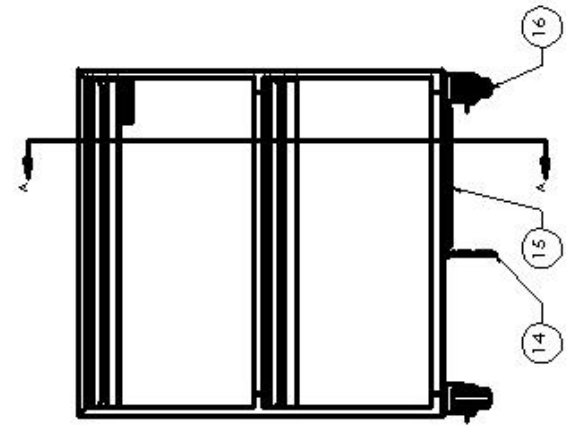
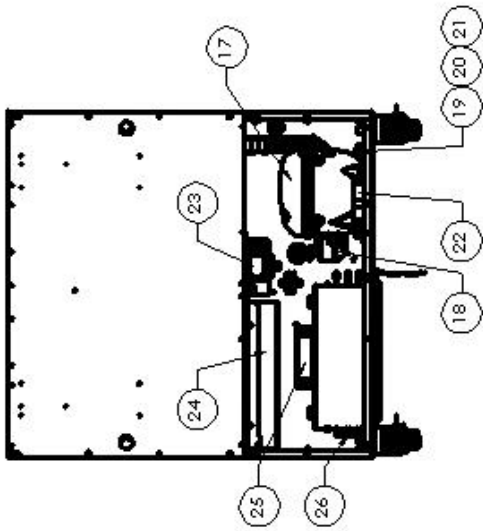

# REPLACEMENT PARTS LIST – SKF27A-ED 115V

ITEM NO.	PART DESCRIPTION	PART NO.
1	DRAWER ASSEMBLY COMPLETE	39959
2	DRAWER GASKET	10310-76
3	KIT SLIDES 15.75" (FOR ONE DRAWER)	10451-04
4		
5		
6		
7	TEMPERATURE INDICATOR	22409
8	POWER CORD 115V	32199
9	DEFROST PROBE EVAPORATOR	38822
	TEMPERATURE PROBE	
10	DEFROST HEATER EVAPORATOR	47076-SK
11	CAPILLARY TUBE EVAPORATOR	99035
12	EVAPORATOR COIL	38337
13	EVAPORATOR FAN MOTOR 115V/230V	39577
14	AIR CURTAIN ASSEMBLY	38353
15	FILTER CONDENSER (OPTIONAL)	31221
16	CASTER KIT 2"	10314-100
	CASTER KIT 3"	10314-63
17	KIT COMPRESSOR W/ ELECTRICALS 115V/60HZ	11700-2
18	KIT ELECTRICALS 115V (RELAY, OVERLOAD, RUN CAPACITOR)	11701-2
19	GROMMET COMPRESSOR MOUNT	20481
20	WASHER COMPRESSOR MOUNT	22401
21	HAIRPIN CLIP COMPRESSOR MOUNT	98106
22	DRIER	22677
23	ELECTRONIC TEMPERATURE CONTROL 115V (PROGRMD)	45768
24	CONDENSATE PAN ASSEMBLY	38379
25	CONDENSER FAN MOTOR 115V/230V	39577
26	CONDENSER COIL	39259
27	REAR PANEL	45250

FORM 45070 REV C

WHEN ORDERING REPLACEMENT PARTS, PLEASE PROVIDE MODEL AND SERIAL NUMBERS.

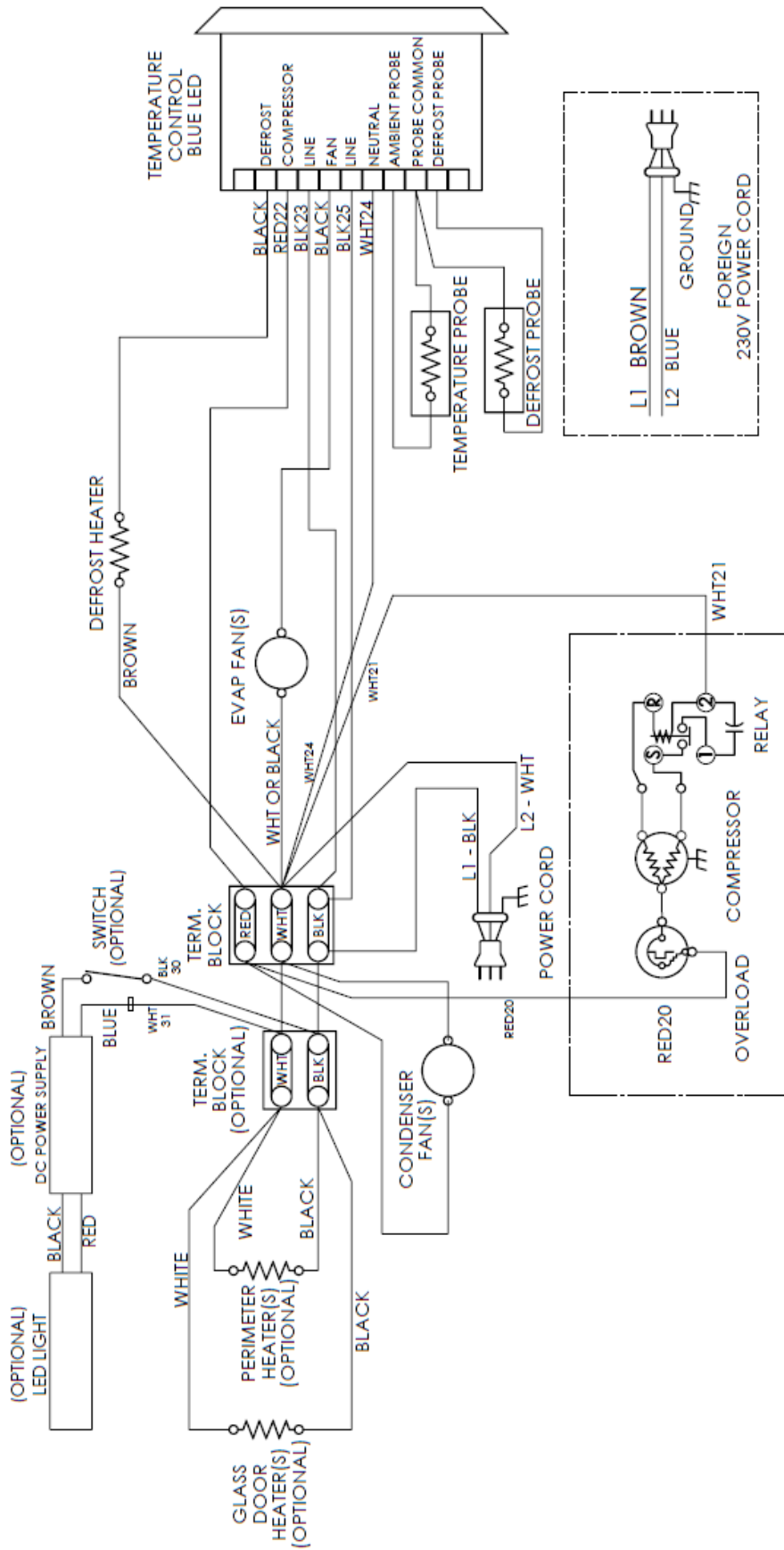

WIRING DIAGRAM  
39767 REV C



# Thermistor Field Testing

Use the guide below to test if a thermistor (temperature probe) is functioning properly. See the replacement parts list for part number information. Table 2 is valid for all thermistors listed on table 1.

## • Establish Thermistor Temperature

- Check the display's temperature reading.
- If a thermometer is available, use it to confirm the display's temperature reading by taking the temperature at the thermistor.
- If the previously stated tasks are unavailable, then use any reasonable means to estimate the thermistors temperature. See form M164 for ice bath method. (ice water is 32 °F)

## • Multimeter Set-up

- Use a multimeter and set it to the resistance ( $\Omega$ ) setting. See Figure 1.
- Disconnect the thermistor from the controller, then connect the multimeter to the thermistor. See Figure 1.
- Check and compare the multimeter's reading to Table 1.

## • Analyze Results

- If the resistance and temperature are similar, then the thermistor is working properly and does not need to be replaced.
- If the resistance and temperature are not similar or the resistance's value is not on Table 1, then the thermistor is not working properly and needs to be replaced.
- If the resistance reads over-limit, then the thermistor is not working properly and needs to be replaced.

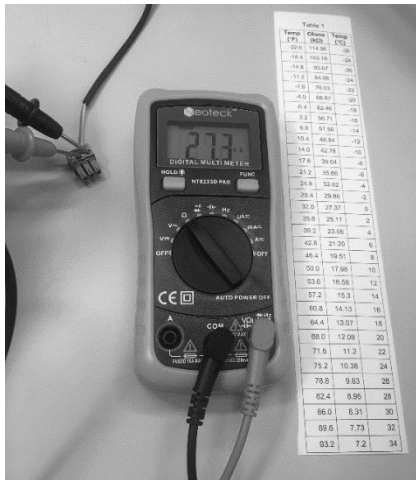

Figure 1

Table 1

Thermistor Description	Part Number
60" black	46128
120" black	46141
60" green	46127
120" green	46140
96" black	38822

Table 2

Temp (°F)	Ohms (k $\Omega$ )	Temp (°C)
-4.0	67.8	-20
-0.4	61.5	-18
3.2	56.0	-16
6.8	51.0	-14
10.4	46.5	-12
14.0	42.5	-10
17.6	38.8	-8
21.2	35.4	-6
24.8	32.4	-4
28.4	29.7	-2
32.0	27.3	0
35.6	25.0	2
39.2	23.0	4
42.8	21.2	6
46.4	19.5	8
50.0	18.0	10
53.6	16.6	12
57.2	15.3	14
60.8	14.1	16
64.4	13.0	18
68.0	12.1	20
71.6	11.2	22
75.2	10.4	24
78.8	9.6	26
82.4	8.9	28
86.0	8.3	30
89.6	7.7	32
93.2	7.2	34
96.8	6.7	36
100.4	6.3	38
104	5.8	40

## **SILVER KING WARRANTY – LEGACY PRODUCT LINE**

Silver King warrants to the original purchaser of every new Silver King Legacy refrigerated self-contained unit (as defined below), that the Equipment shall be free from defects in material and workmanship under normal use and service as outlined in the Technical Manual for a period of one (1) year from the later of either (a) the date of shipment from the manufacturer or (b) the date of installation (the "Warranty Period"), but in no event shall the Warranty Period commence later than six (6) months from the date of shipment from the manufacturer unless otherwise agreed upon by the parties in writing. Equipment includes General Market Refrigeration units and excludes all Dispensing and Custom Holding Refrigeration or extended agreements whose written terms are conditional at time of sale or contract. All warranties are subject to specific limitations outlined below.

This Equipment warranty does not apply to: Repair or replacement required as a result of carelessness or neglect. Improper installation, incorrect voltage supply, modifying, tampering with or altering components and/or Equipment. Failure to perform proper maintenance. This warranty does not apply to damage resulting from fire, water, burglary, accident, abuse, misuse, transit, acts of God, terrorism, attempted repairs, improper installation or maintenance by unauthorized persons, and does not apply to food loss. Unit is compromised by adding excess weight or adhering nonapproved components to the frame. Combining the equipment with hardware, fixtures, accessories or other equipment not provided by Silver King. Misuse of the Equipment or use of the Equipment not in accordance with the Technical Manual. Warranty excludes consumables or replacement components such as shelving, trays, gaskets, etc. Warranty excludes interior liner or exterior shell. Condensing coils must be cleaned at regular intervals. Failure to do so can cause compressor malfunction and will void warranty. Although cleaning requirements vary in accordance with operation of various products, Silver King advocates a minimum monthly cleaning.

The Equipment warranty does not include freight, handling, installation, labor (following the (1) year labor warranty period) or other incidental or consequential costs including product and/or economic loss. This Equipment warranty is in lieu of all other warranties, express or implied, are hereby disclaimed and excluded including those of merchantability, and fitness for a particular purpose. This Equipment warranty is non-transferable. Specific provisions of this Equipment warranty are as follows:

**90 DAY REPLACEMENT PARTS WARRANTY** Silver King warrants to the original Equipment purchaser that a replacement OEM part thereof will be free of defects in material and workmanship, under normal use and service, for a period of 90 days from the date of original purchase of such replacement OEM part subject to all terms and conditions herein.

**LIFETIME HINGE AND HANDLE WARRANTY** Silver King provides a lifetime warranty on hinges and primary (door or drawer) handles. In the event of a non-conforming hinge or primary handle, Silver King shall provide a replacement part; however, Purchaser shall be responsible for any other replacement costs, including but not limited to shipping, installation and labor.

**Three (3) Year Drawer Slide Warranty** Silver King warrants to the original Equipment purchaser for a period of time not to exceed the earlier of the following: three (3) years from the date of original purchase of the Equipment or three (3) years and six (6) months from the date of shipment from the factory of the equipment, that it will replace the drawer slides with one of similar design and capacity, exclusive of delivery and installation charges, if it is found in Silver King's review to be inefficient or inoperative due to defects in material or factory workmanship.

**FIVE (5) YEAR COMPRESSOR WARRANTY** Silver King warrants to the original Equipment purchaser for a period of time not to exceed the following: five (5) years from the date of original purchase of the Equipment or five (5) years and six (6) months from the date of shipment from the factory of the Equipment, that it will replace the compressor with one of similar design and capacity, exclusive of delivery and installation charges, if it is found subject to Silver King's review to be inefficient or inoperative due to defects in material or factory workmanship. It is the original purchaser's responsibility to return the serial plate of the defective compressor, or at Silver King's option the complete compressor,

to the factory. Failure to do so will void this limited compressor warranty. This limited compressor warranty shall be limited to parts only after the WARRANTY period applicable to the Equipment has expired.

This Equipment warranty is limited to repairing or replacing any parts that, at Silver King's discretion, are deemed to be defective within the time period covered by this warranty. The three (3) year parts warranty covers standard freight and handling charges. Special handling charges or expedited means for transport are excluded from reimbursement. Use of non-OEM parts may, at Silver King's discretion, void this warranty. If approved, warranty credit for non-OEM parts will be issued at the OEM cost. Replacement parts sold separately are warranted for 90-days from date of purchase. Special installation/applications, including remote locations, are limited in coverage by this warranty. Any installation that requires extra work, and or travel, is the sole responsibility of the equipment purchaser.

**ADDITIONAL WARRANTY GUIDELINES:** A factory issued Service Authorization Number must be obtained prior to work being performed under the (1) one-year labor warranty. Contact your supplier or Silver King. Claims submitted without a Service Authorization Number will be paid at Silver King's discretion. The labor warranty includes standard straight time labor charges in accordance with Silver King's Labor Warranty Guidelines and reasonable travel time, as determined as determined in the Silver King time – rate guide.

Silver King, at its discretion, may request photos during or prior to service being dispatched to validate a technical issue. Failure to comply with the request may result in the cost of service being the responsibility of the service requestor or site.

The labor warranty does not cover original installation, startup, normal adjustments or maintenance. Normal adjustments and maintenance include, but are not limited to; temperature control adjustments, temperature indicator calibrations, coil and filter cleaning, or condensate drain cleaning.

A second service call for a related failure is not covered.

Use of refrigerants other than specified on the Equipment serial plate voids the warranty. All claims must include; model and serial number of equipment, date of purchase, date of failure, and a copy of the service invoice detailing the defect and service performed. No claim will be processed without this information. All claims must be filed within 30 days from date of service.

**PRODUCT ORDERING INFORMATION** Call us toll free at 1-800-328-3329 or 1-763-923-2441 Fax us at 1-763-553-1209

Visit [www.silverking.com](http://www.silverking.com) for stocking distributor, equipment specs and current price list for your area.

**SERVICE / PARTS ORDERING INFORMATION** Call us toll free at 1-800-328-3329, prompt 1 Equipment Service and Tech Support or 2 Parts

**TERMS AND CONDITIONS** • This price list and conditions are effective January 1, 2020 and supersedes all previous price lists. •WARRANTY period may vary from customer to customer and is contract specific. • All prices reflect payment in U.S. Dollars. • Prices do not include any freight, duty, or taxes. • Pricing subject to change without notice. • No returns are accepted without prior written approval from the factory. An RMA (Returned Merchandise Authorization) form must be completed and then approved by Silver King. Please contact Silver King for details. Restocking fee will apply. • All electrical equipment is single phase. • Prices, designs, and specifications are subject to change without notice. • Payments via credit card are subject to a 3.5% surcharge. •

Any and all environmental attributes, including environmental offset credit rights, with respect to Silver King refrigeration units manufactured after September 1, 2015, shall remain the property of Silver King and are not transferred.

IN NO EVENT SHALL SILVER KING BE LIABLE FOR CONSEQUENTIAL, SPECIAL OR PUNITIVE DAMAGES. THE REMEDIES OF PURCHASER SET FORTH HEREIN ARE EXCLUSIVE AND THE TOTAL LIABILITY OF SILVER KING, WHETHER BASED ON

CONTRACT, WARRANTY, NEGLIGENCE, INDEMNIFICATION, STRICT LIABILITY, TORT, OR OTHERWISE, SHALL NOT EXCEED THE PURCHASE PRICE OF THE COMPONENT UPON WHICH LIABILITY IS BASED. SILVER KING SHALL HAVE NO OBLIGATION OR LIABILITY FOR CONSEQUENTIAL OR SPECIAL DAMAGES, INCLUDING BUT NOT LIMITED TO INDIRECT, PUNITIVE DAMAGES, LOSS OF USE, LOSS OF PRODUCT, DOWNTIME OR LOST PROFITS, ARISING OUT OR, RELATED TO OR CONNECTED IN ANY WAY WITH THE PRODUCT OR ITS USE.

Silver King 1600 Xenium Lane, Plymouth, MN 55441-3706 [www.silverking.com](http://www.silverking.com) • 1-800-328-3329

© Silver King 2019 Prices Subject To Change

*Note: Additional Terms and Conditions of sale may apply. Notice: Specifications Subject to Change Without Notice. Contact factory for specific model agency approval.*

46267 REV A