



Features

Eco-Friendly Refrigerant

R290 refrigerant with a global warming potential (GWP) of 3

Quick-Load Milk Crates

Loading product is simple with the auto-align connector slot that ensures correct positioning — an additional platform accessory is available to accommodate bag-in-box

Minimal Waste

Angled milk crate design pushes product toward the dispense point to maximize yield

Made to Last

Stainless steel exterior with galvanized bottom reduces the risk of corrosion

Long-Lasting, Removable Gaskets

Santoprene™ gaskets last four times longer than standard gaskets

High-Density Insulation

Foamed-in-place, CFC-free polyurethane insulation provides maximum strength, rigidity, and insulation

High-Capacity

Each milk crate can hold a 3-gallon, 5-gallon, or 6-gallon bag — also accommodates a bag-in-box and manual-fill stainless steel can

Single Valve Dripleless Dispense

Spring-loaded lift valve ensures dripleless dispense for optimal sanitation, reduced waste, and convenient one-handed operation

Easy to Clean

The stainless steel interior with coved corners, finished edges, removable door gasket, and elevated legs make cleaning simple

Heavy-Duty, Locking Door

High-strength door with heavy-duty hinges ensure lasting performance — latch can accommodate locks and security tags

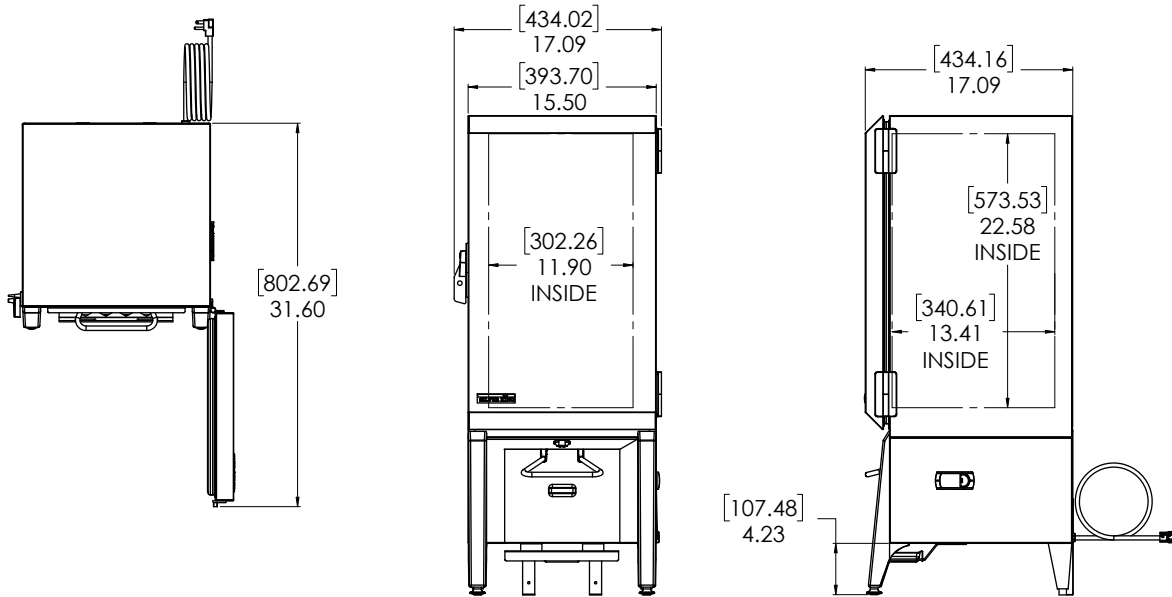

Technical Specifications

Electrical Requirements	115v/60hz/1ph/1.6A/NEMA 5-15P Plug
Product Dimensions	17.09"W x 17.09"H x 39.48"D (43.41cm x 43.41cm x 100.28cm)
Product Weight	110lbs (49.90kg)
Shipping Dimensions	25"W x 26"H x 48"D (63.50cm x 66.04cm x 121.92cm)
Shipping Weight	120lbs (54.43kg)
Shipping Cubic Dimensions	18.06ft ³ (0.51Cu.M)
Temperature Range	38 to 40°F (3.3 to 4.4°C)
Refrigerant	R290
Charge Level	2.26oz (64.1 grams)
Insulation	Foamed-in-place, CFC-free polyurethane

Exterior Construction	Stainless steel exterior with galvanized bottom
Interior Construction	Stainless steel interior with coved corners and finished edges
Doors	One (1) right-hand swing with lockable latch
Valves	One (1) spring-loaded lift valve
Crates	One (1) milk crate (accommodates 3-gallon, 5-gallon, or 6-gallon bags)
Internal Capacity	6-Gallons
Door Gasket	Long-lasting, removeable Santoprene™ gasket
Legs	Adjustable standard legs or adjustable shipboard legs
Certifications	ETL SAFETY, ETL SANITATION NSF 7
Warranty	1-year parts and labor, 5-year compressor (part only)

Model Number	Description
SKMAJ1-ESUS3	Majestic Milk Dispenser, 115v/60hz/1ph/1.6A, 1 valve, (1) 6-gallon crates, shipboard legs, NEMA 5-15P
SKMAJ1-ESUS4	Majestic Milk Dispenser, 115v/60hz/1ph/1.6A, 1 valve, (1) 6-gallon crates, adjustable legs, NEMA 5-15P

Accessories	Description
35904	Milk Crate for 3-Gallon, 5-Gallon, or 6-Gallon Bags
62642	3-Gallon Milk Can
60224	5-Gallon Milk Can
63959	Platform Adaptor for Bag-in-Box
20323	Milk Tubes
10314-96	Shipboard Legs

To learn more about **Milk Dispenser**, visit silverking.com