

36" Fountainette

SKRN36-RS



Silver King® is the leader in reliable and energy efficient refrigeration solutions. Our sleek, stainless steel Fountainettes are made with the highest quality materials to guarantee everything is kept fresh and meets temperature standards. Our Fountainettes have polyurethane insulation for maximum strength, durability, and minimal energy waste.

Standard Features

- Exterior stainless steel.
- Aluminum interior, coved corners and finished edges for easy cleaning.
- Environmentally friendly polyurethane foamed-in-place insulation for maximum strength and durability.
- Standard 8 foot 3 wire power cord.
- CFC-free, R134A refrigerant, hermetically sealed, high efficiency, self contained refrigeration system with automatic defrost.
- Heavy gauge wire shelves are hand dipped, not sprayed, providing double thick epoxy coating for superior durability and smooth finish. Adjustable in 2" increments on stainless steel pilasters.
- Limited Warranty: one year parts and labor, with an additional two years on parts, and additional three years on the compressor (five year compressor warranty).

Specifications

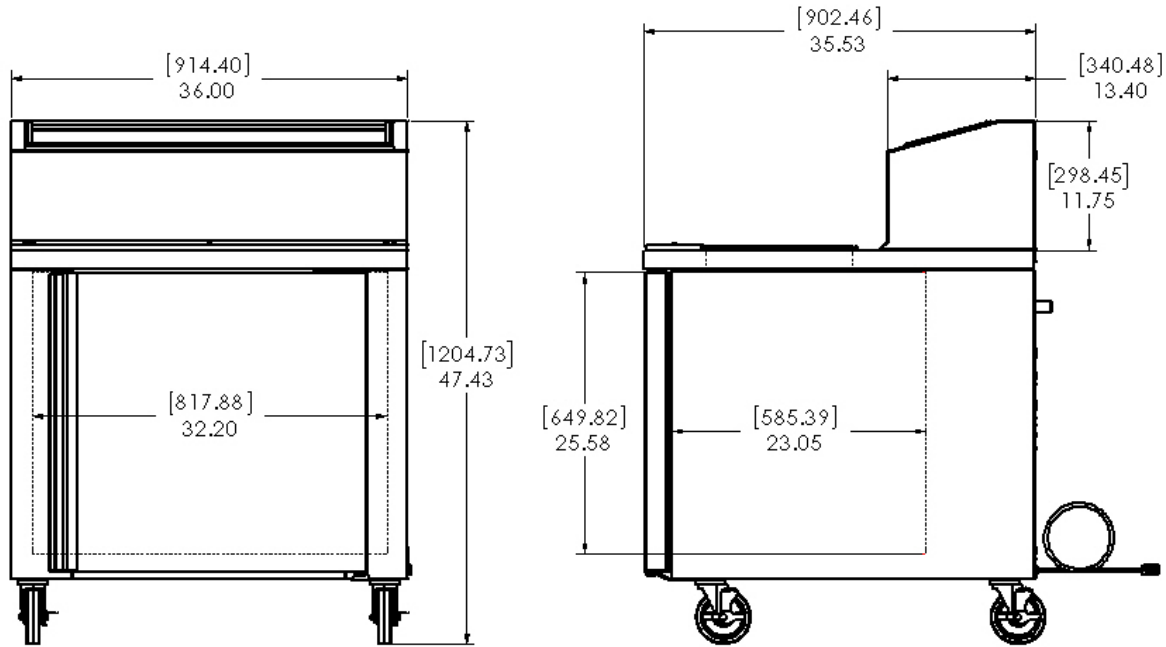

Dimensions

Model Number	Width in (mm)	Height in (mm)	Depth in (mm)	Gross Shipping Weight lb (kg)	Unit Net Weight lb (kg)	Shipping cu ft (cu m)
SKRN36-RSUS1	36 (914.40)	47.43 (1204.73)	35.53 (902.46)	275 (124.74)	250 (113.40)	51.82 (1.47)

Electrical

Model Number	Country	Amps	Voltage	Hz	Plug
SKRN36-RSUS1	USA	3.39	115 VAC	60 Hz	NEMA 5-15P

Certifications

