

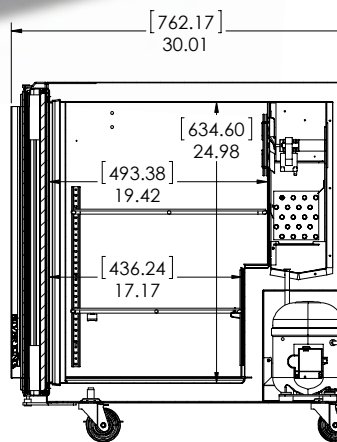

Refrigerator

MODEL SKR48/C2



32]
48

SECTION A-A

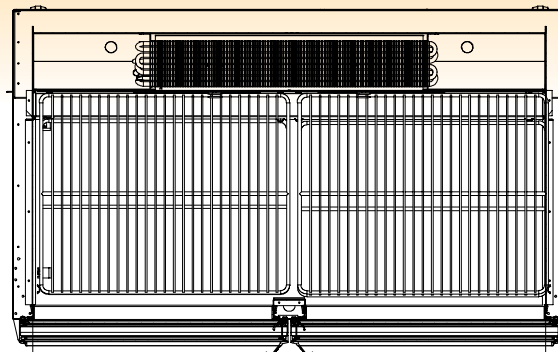

SECTION B-B

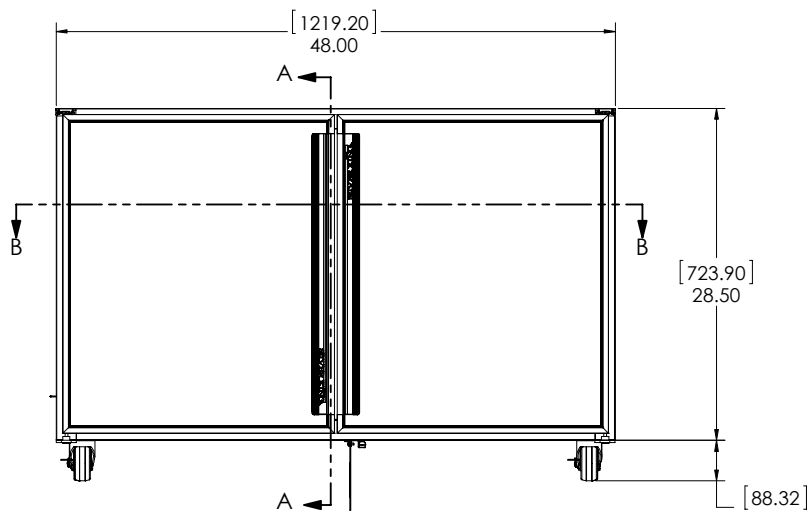

MODEL	LENGTH	DEPTH	HEIGHT	COMPRESSOR	AMPS	WEIGHT
SKR48/C2	48"	30.01"	31.98"	1/4 HP	3.05	250 lbs.

- EXTERIOR** Stainless steel. Galvanized back and bottom.
- INTERIOR** Aluminum. Coved corners and finished edges for ease of cleaning.
- INSULATION** Environmentally friendly foamed-in-place polyurethane for maximum strength and durability.
- DOORS** Heavy-duty magnetic "Thermo Rubber" door gaskets combine to make the toughest, longest lasting door in the industry.
- SHELVES** Heavy gage wire shelves are hand dipped, not sprayed, providing double-thick epoxy coating for superior durability and smooth finish, with bottle slides.
- REFRIGERATION** CFC-free, R134a refrigerant, hermetically sealed, high efficiency, self contained refrigeration system. Automatic condensate evaporator means no plumbing or floor drains.
- LISTINGS** ETL Safety (U.S. and Canada), ETL Sanitation.



1600 Xenium Lane North
 Minneapolis, MN 55441-3787
 Phone (763) 923-2441
 Fax (763) 553-1209
 www.silverking.com



Specifications subject to change without notice.

2/2013
 © Silver King 2013
 Printed in U.S.A.