

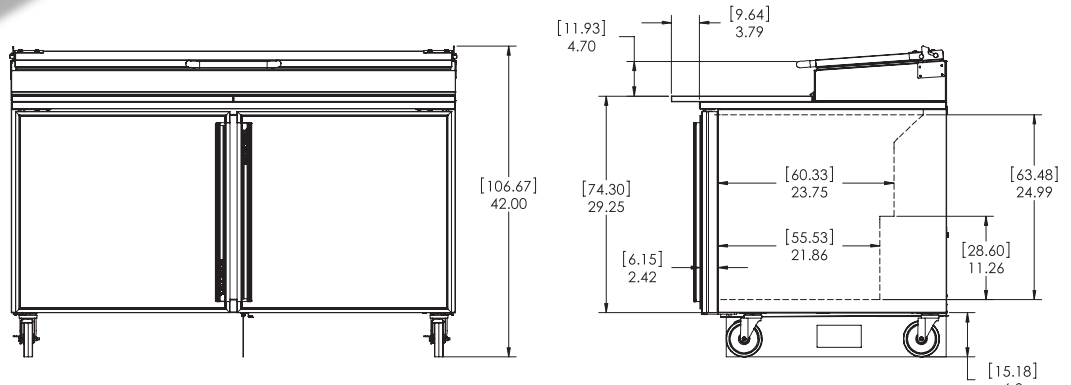

# Refrigerated Prep Table

MODEL SKPZ60/C2

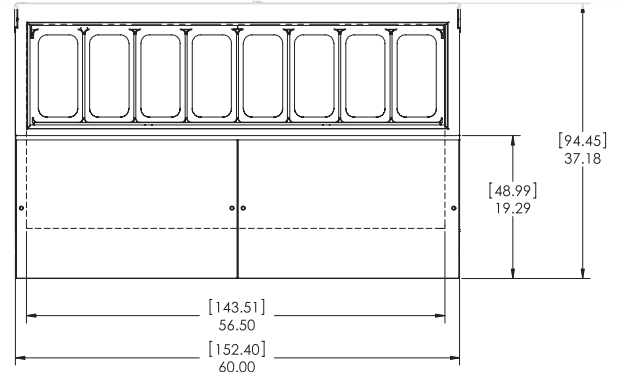

MODEL	LENGTH	DEPTH	HEIGHT	COMPRESSOR	AMPS	WEIGHT
SKPZ60/C2	60"	37.18"	42"	1/3 HP	8.5	470 lbs.

<b>EXTERIOR</b>	Stainless steel. Galvanized back and bottom.
<b>INTERIOR</b>	Aluminum. Coved corners and finished edges for ease of cleaning.
<b>INSULATION</b>	Environmentally friendly foamed-in-place polyurethane for maximum strength and durability.
<b>DOORS</b>	Heavy-duty magnetic "Thermo Rubber" door gaskets combine to make the toughest, longest lasting door in the industry.
<b>SHELVES</b>	Heavy gage wire shelves are hand dipped, not sprayed, providing double-thick epoxy coating for superior durability and smooth finish.
<b>REFRIGERATION</b>	CFC-free, R404a refrigerant, hermetically sealed, high efficiency, self contained refrigeration system. Automatic condensate evaporator means no plumbing or floor drains.
<b>DOOR GASKETS</b>	Santo Prene material lasts four times industry standard.
<b>ELECTRICAL</b>	Standard 115 volt, 60 Hz, single phase operation with 8 foot, 3 wire power cord with NEMA 5-15P plug.
<b>LISTINGS</b>	ETL Safety (U.S. and Canada), ETL Sanitation.



1600 Xenium Lane North  
 Minneapolis, MN 55441-3787  
 Phone (763) 923-2441  
 Fax (763) 553-1209  
[www.silverking.com](http://www.silverking.com)



Specifications subject to change without notice.

10/2013  
 © Silver King 2013  
 Printed in U.S.A.