

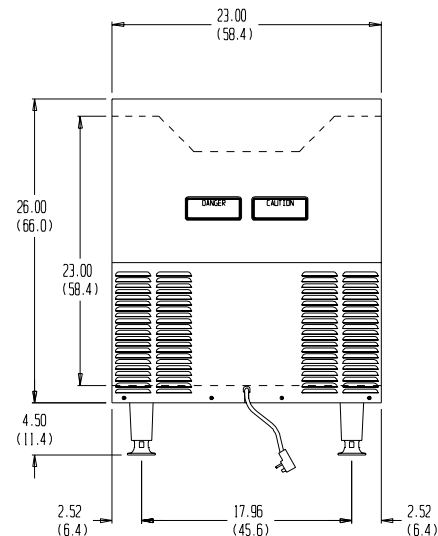

# Refrigerated Display Case

MODEL SKDC48/C1

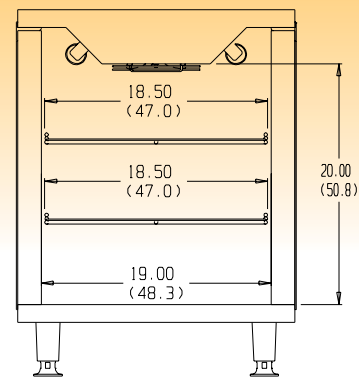
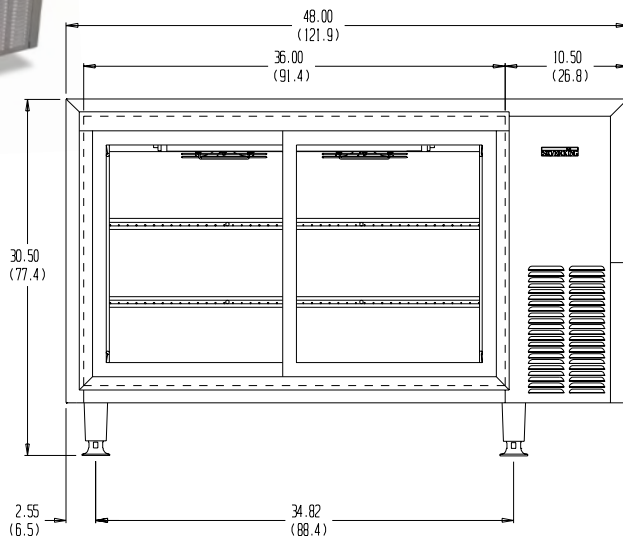

MODEL	LENGTH	DEPTH	HEIGHT	COMPRESSOR	AMPS	WEIGHT
SKDC48/C1	48"	23"	25"	1/4 HP	3.9	300 lbs.

- EXTERIOR** Stainless steel.
- INTERIOR** Aluminum. Coved corners and finished edges for ease of cleaning.
- INSULATION** Environmentally friendly foamed-in-place polyurethane for maximum strength and durability.
- DOORS** Heavy Duty glass door. "Thermo Rubber" door gaskets combine to make the toughest, longest lasting door in the industry.
- SHELVES** Heavy gage wire shelves are hand dipped, not sprayed, providing double-thick epoxy coating for superior durability and smooth finish, with bottle slides.
- REFRIGERATION** CFC-free, R134a refrigerant, hermetically sealed, high efficiency, self contained refrigeration system. Automatic condensate evaporator means no plumbing or floor drains.
- ELECTRICAL** Standard as 115 volt, 60 Hz, single phase operation with 8 foot, 3 wire power cord with NEMA 5-15P plug. Also available in 230 volt, 50 hz, single phase.
- LISTINGS** ETL Safety (U.S. and Canada), ETL Sanitation.
- WARRANTY** One year parts and labor. Five year warranty on compressor.



1600 Xenium Lane North  
 Minneapolis, MN 55441-3787  
 Phone (763) 923-2441  
 Fax (763) 553-1209  
 www.silverking.com



Specifications subject to change without notice.

2/13  
 © Silver King 2013  
 Printed in U.S.A.