

# DEEPWELL FREEZER UNITS

## NEW AND IMPROVED

Model SKMWF34



## HIGHER CAPACITY

- Increased Storage Versatility
- Improved Ergonomics
- Easier Access to More Products



Model SKMWF44



Model SKMWF50

# DEEPWELL FREEZERS

## Models SKMWF34, SKMWF44, SKMWF50

EXTERIOR	Stainless steel front, back and sides. Bumpers standard to protect cabinet.
INTERIOR	Stainless steel with covered corners and finished edges for easy cleaning. Drain with plug standard.
INSULATION	Environmentally friendly foamed-in-place polyurethane insulation for maximum strength and durability.
COVER	Insulated stainless steel, easy slide covers.
CASTERS	Supplied with 4-(5") heavy-duty plate casters, (two with locks) for easy mobility.
REFRIGERATION	CFC-free, R-404a refrigerant, hermetically sealed, high efficiency, self contained refrigeration system features cold wall design with anti-condensate heater to prevent frost build-up on door track. Adjustable temperature control and digital temperature indicator standard. Manual defrost. High efficiency forced air condenser.
ELECTRICAL	Standard as 115 volt, 60Hz, single phase operation. 8 foot, 3-wire power cord with NEMA 5-15 plug. Available in 220 volt 50/60Hz, single phase.
ACCESSORIES	Optional basket (#35949), container (#36309) and lid (#36310) available.
LISTINGS	UL (U.S. and Canada), NSF International.
WARRANTY	One year materials and workmanship warranty on cabinet. Five year warranty on compressor.

MODEL	HEIGHT	WIDTH	DEPTH	STORAGE CAPACITY	AMPS	COMPRESSOR	SHIPPING WEIGHT
SKMWF34	35.23	34"	24.76"	4.53 CU. FT	5.7	1/2 hp	205 lbs.
SKMWF44	35.23"	44"	24.75"	6.09 CU. FT.	6.8	1/2 hp	235 lbs.
SKMWF50	35.23"	50"	24.75"	7.03 CU. FT.	6.9	1/2 hp	260 lbs.

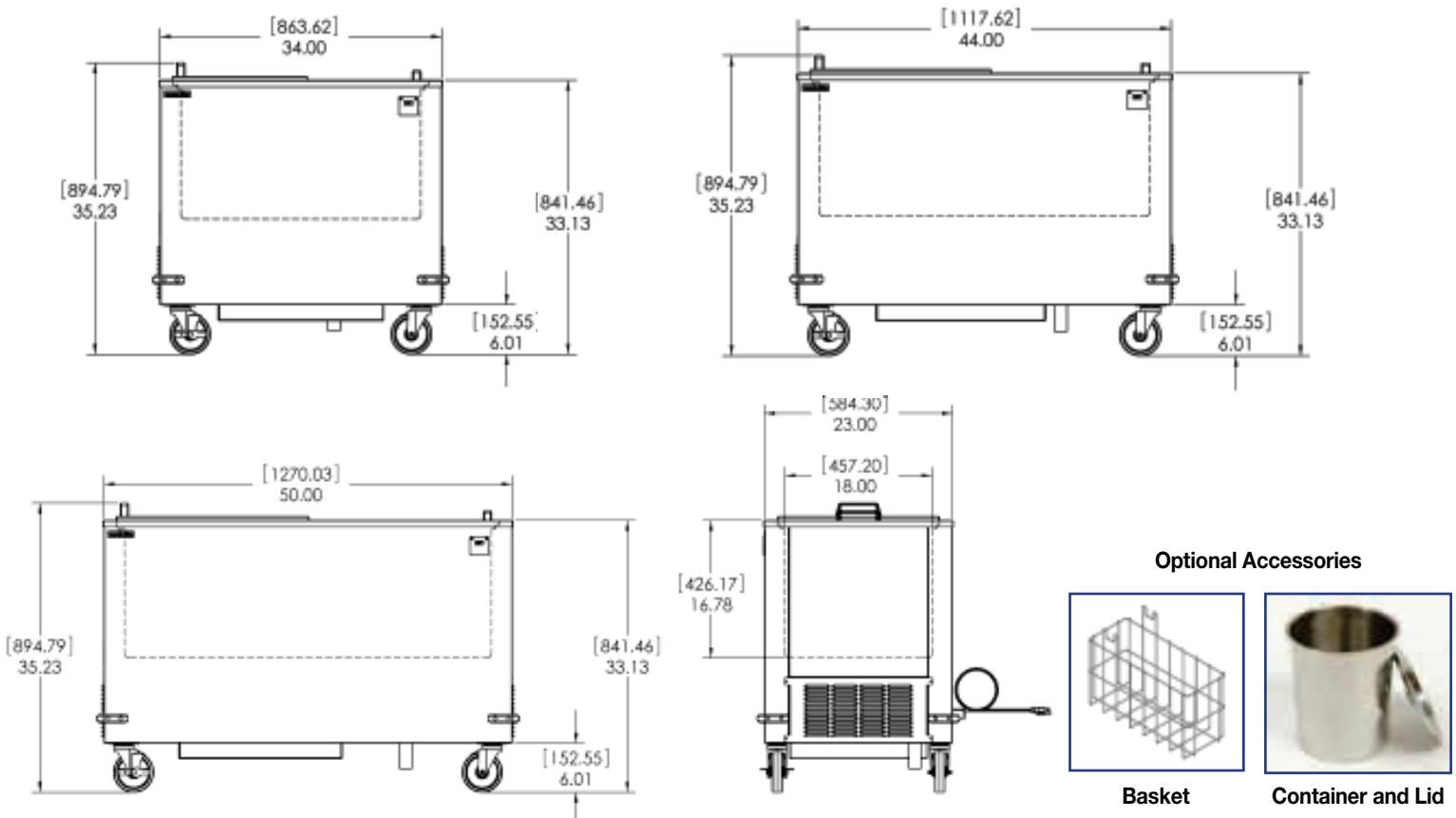

1600 Xenium Lane North  
 Minneapolis, MN 55441-3787  
 Phone (763) 923-2441  
 Fax (763) 553-1209  
[www.silverking.com](http://www.silverking.com)



Specifications subject to change without notice.

7/10/2010  
 © Silver King 2010  
 Printed in U.S.A.